

Parts List and Diagram for Model 160-WP-SS

Stainless Steel 4-Wheel Drum Truck with Pneumatic Wheels

Serial Number 1215 to _____

For replacement parts, please contact your Morse dealer.

When ordering parts, please specify:

- Part number and description
- Model number

Assembly Instructions

1. Insert Hook Weld (item 6) into tube of drum truck base with holes aligned.
2. Install handle onto drum truck base. Secure with 2 screws (item 3) using 7/32" hex wrench.

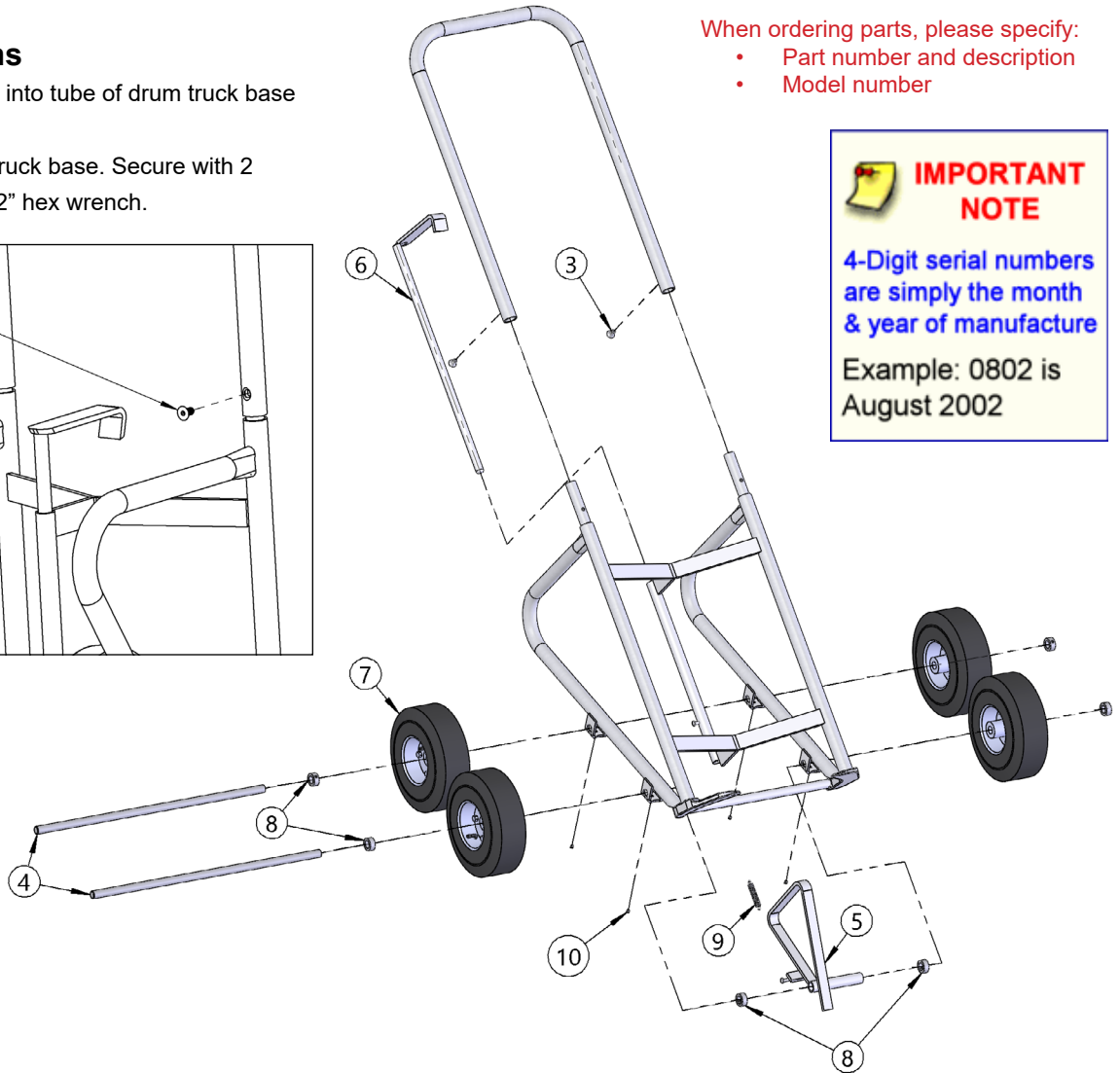
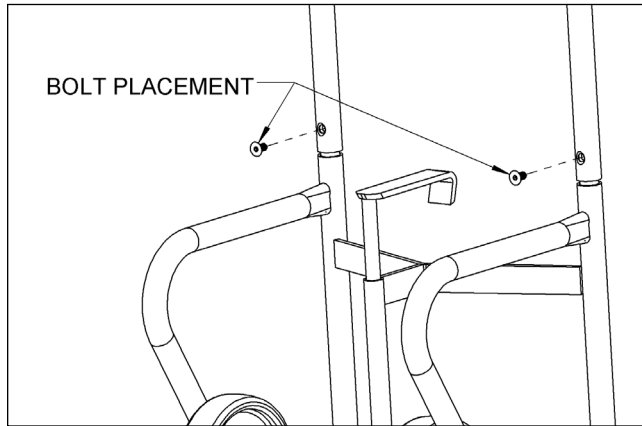

IMPORTANT NOTE

4-Digit serial numbers are simply the month & year of manufacture

Example: 0802 is August 2002



WARNING: This product can expose you to chemicals including barium sulfate, cobalt, titanium dioxide, and 2-methylimidazole, which are known to the State of California to cause cancer, and bisphenol-A, which is known to the State of California to cause birth defects or other reproductive harm.

For more information go to www.P65Warnings.ca.gov

ITEM NO.	PART NUMBER	DESCRIPTION	QTY.
3	4685SS-P	SHCS, 3/8-16 X 3/4 FH, SS	2
4	1381SS-P	AXLE, 25.5", 160-WP-SS	2
5	2752-P	STAND WELD, 160-SS	1
6	5941SS-P	HOOK WELD, 160-SS	1
7	1379-P	WHEEL, PNEUMATIC 10", 160-WP	4
8	15SS-P	COLLAR, 3/4" ID, SS	6
9	1114SS-P	SPRING, EXTENSION, SS, 160-SS	1
10	1000SS-P	SET SCREW, 1/4-20 X 1/4, SS	4